



# Panther Military RC Series 2.5" MLC SATA3 SSD with Nebula Rugged SATA Connector

## Data Sheet





Straddle Connector

Cable Connector

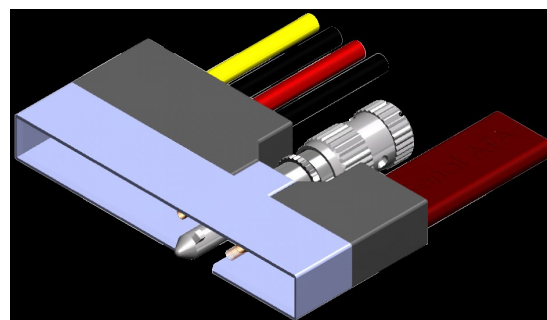

**Connector with Extreme Rugged Performance**

- Operating Shock 3,000 G, 0.5 ms, 1/2 sine, 6 shocks per axis 100 G, 11 ms, 1/2 sine, 6 shocks per axis
- Vibration 30 Grms, Mil-STD-810F/G, method 514.5C-8, 15-2000 Hz, 3 axes (1.5 hr. each axis)
- Temperature Range -55 to 125°C Mating/ Unmating Cycles 100,000
- Mating Cycles with little to no performance degradation.



**Table of Contents**

**1. Introduction** ..... 5

    1.1 General Description..... 5

    1.2 Key Features ..... 5

**2. General Product Specifications** ..... 7

    2.1 Block Diagram..... 7

    2.2 Interface ..... 7

    2.3 Capacity ..... 7

    2.4 Performance ..... 8

    2.5 Power Consumption ..... 8

    2.6 Endurance..... 8

**3. Physical Specification** ..... 9

**4. Interface** ..... 10

    4.1 Supported Standards..... 10

    4.2 Pin Assignments..... 11

**5. Environmental Specifications** ..... 11

    5.1 Temperature..... 11

    5.2 Humidity ..... 12

    5.3 Vibration ..... 12

    5.4 Shock ..... 12

    5.5 Altitude ..... 12

    5.6 Electrostatic Discharge (ESD)..... 12

**6. Reliability Characteristics** ..... 13

    6.1 Error and Bad Block Management ..... 13

    6.2 Global Wear-leveling ..... 13

    6.3 Garbage Collection ..... 13



**7. Supported ATA Commands** ..... 13

    7.1 Command Set ..... 13

    7.2 Identify Data ..... 15

    7.3 SMART Feature Set ..... 17

    7.4 SMART Data Structure ..... 18

    7.5 SMART Attributes ..... 19

**8. Ordering Information** ..... 20

**Ideal for Different Types of Military Applications:**

**Aerospace, Avionics and Ground Vehicle applications, Helicopters, Command, Control, Communications, Computers, Intelligence, Surveillance, Surface-to-Air Missile (SAM), or Ground-to-Air Missile (GTAM) etc....**



**Confident in the enhanced reliability features of Military Grade Panther Series solid-state drive (SSD), SDKSys announced it has extended its limited warranty for the Military Grade Panther Series from three years to five years.  
The extended warranty term will apply to all Military Grade Panther Series drives.**



## 1. Introduction

### 1.1 General Description

Panther RC series 2.5" SATA 6Gbps rugged SSD is based on proven new-generation controller, firmware, and reliable MLC Nand Flash Memory technologies. Rigorous qualification in various industrial applications and compatibility testing ensures RC series rugged SSDs highly reliable.

To face the challenge of satisfying wide temperature (WT) working requirements, SDKSys utilizes its unique IC level tests for key IC components like Nand flash chips, and system level burning-in tests for the entire SSD solution, too ensure the products meet and exceed extreme WT operating conditions, which range from -40°C to +85°C.

The advanced flash management technology designed into the device firmware allows it to achieve superior sequential and random IO performance, and improves long-term data endurance significantly. The device firmware also implements functions of Dynamic bad block management, global wear-leveling, and robust error correction code (ECC) to ensure data integrity.

### 1.2 Key Features

- Smith Nebula Rugged SATA connector
- SATA 6Gbps high-performance
- Power failure recovery (Built-in voltage detectors for power failure protection Built-in power-on reset and voltage regulators)
- Supports data security erase and quick erase
- Conformal coating (Optional)
- Secure Erase Executed by Hardware Trigger (Optional)
- Software/ Hardware write protection (Optional)

#### Host interface

- Industrial Standard SATA Revision 3.1 compliant
- Industrial Standard ATA/ATAPI-8 and ACS2 command compliant
- Supports SATA interface rate of 6Gb/s (backward compatible to 1.5Gb/s and 3Gb/s)
- Native Command Queuing up to 32 commands
- SATA Device Sleep (DevSleep)
- Data Set Management command (TRIM)
- Self-Monitoring, Analysis, and Reporting Technology (S.M.A.R.T.)
- Supports PHY Sleep mode (CFast PHYSLP)
- Supports 28-bit and 48-bit LBA (Logical Block Addressing)
- NCQ support up to queue depth=32
- Mode commands



### High performance

- Sustained Sequential Read: 560 MB/s
- Sustained Sequential Write: 470 MB/s
- 4K Random Read: 77,000 IOPS
- 4K Random Write: 73,000 IOPS

### Low power consumption

- Max read/write: 2.75/ 3.50W
- Slumber power mode: 0.60W

### Advanced Flash Management

- TRIM Support
- Global wear leveling algorithm evens program/erase count and maximizes SSD lifespan
- Bad Block Management
- Background Garbage Collection
- Hardware BCH ECC capable of correcting errors up to 66-bit/1KB

### Advanced power management

- Built-in voltage detectors for power failure protection
- Automatic sleep and wake-up mechanism to save power
- Built-in power-on reset and voltage regulators

### Ultra-reliable

- Data retention: 10 years @25C
- MTBF: >3,000,000 Hours @25C
- Compliant with MIL-STD-810F/G
- Operating shock: 2,000G, 0.4 ms; 50G, 11ms
- Operating vibration: 20G, 10-2,000 Hz random
- Operating temperature: -40°C to +85°C
- Storage temperature: -55°C to +95°C
- Static Data Refresh technology ensures data integrity
- Early weak block retirement option
- Internal data shaping technique increases data endurance
- Built-in voltage detectors for power failure protection
- Built-in power-on reset and voltage regulators
- Built-in temperature sensor for SSD temperature detection

### Enhanced Security

- Real time full drive encryption with AES
- TCG Opal protocol
- Hardware SHA 256 and TRNG



## 2. General Product Specifications

### 2.1 Block Diagram

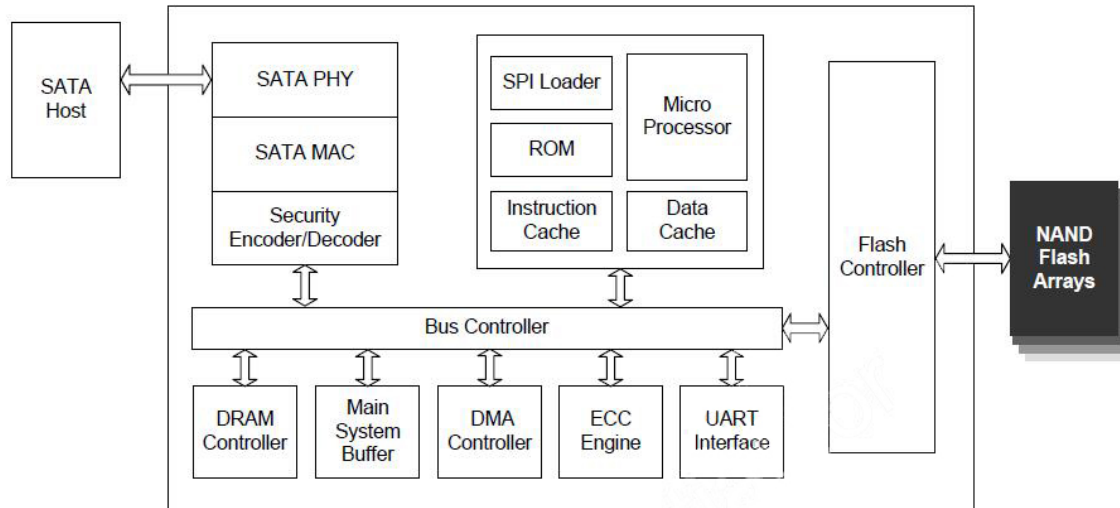

Table 2- 1: Block Diagram

### 2.2 Interface

RC series 2.5" SATA 6Gbps rugged SSD complies with the Serial ATA standard published by ANSI. The device complies with the SATA 6Gbps, Revision 3.1 specifications and supports ATA Command Set ACS-2.

### 2.3 Capacity

Unformatted Capacity	Logical Cylinders	Logical Heads	Logical Sectors per Track	Total Sectors
<b>16GB</b>	16383	16	63	30,932,992
<b>32GB</b>	16383	16	63	61,865,984
<b>64GB</b>	16383	16	63	123,731,968
<b>128GB</b>	16383	16	63	247,463,936
<b>256GB</b>	16383	16	63	494,927,872
<b>512GB</b>	16383	16	63	989,855,744
<b>1TB</b>	16383	16	63	1,979,711,488

Table 2- 2: Capacity Specification



## 2.4 Performance

Capacity	ATTO R/W(MB/s)		AS SSD ((MB/s)				IOmeter 2008	
			Seq. R/W		4KB R/W		4KB-R	4KB-W
<b>16GB</b>	210	100	209.30	98.97	28.21	70.45	NA	NA
<b>32GB</b>	410	220	408.22	217.25	30.21	75.23	NA	NA
<b>64GB</b>	561	481	548.30	450.97	38.21	83.45	77,000	72,000
<b>128GB</b>	561	484	522.43	459.32	38.59	86.04	77,000	72,000
<b>256GB</b>	561	491	523.53	459.32	38.62	86.05	77,000	73,000
<b>512GB</b>	561	491	523.53	459.32	38.62	86.05	77,000	73,000
<b>1TB</b>	560	470	523.53	459.32	38.59	86.04	77,000	73,000

Table 2- 3: Performance Specification

## 2.5 Power Consumption

Input Voltage: 5V±5%

Capacity	Idle	Read	Write	Unit
32GB	0.29	0.91	0.97	W
64GB	0.28	1.10	1.36	W
128GB	0.27	1.11	1.97	W
256GB	0.25	1.19	2.94	W
512GB	0.25	1.20	2.98	W
1TB	0.30	1.50	3.23	W

Table 2- 4: Power Consumption Specification

## 2.6 Endurance

Capacity	32GB	64GB	128GB	256GB	512GB	1TB
Data Retention	>10 years					
Read	Unlimited					
Write	96.87TB	193.74TB	387.48TB	774.95TB	1549.9TB	3099.81TB

Table 2- 5: Endurance Specification





### 3. Physical Specification

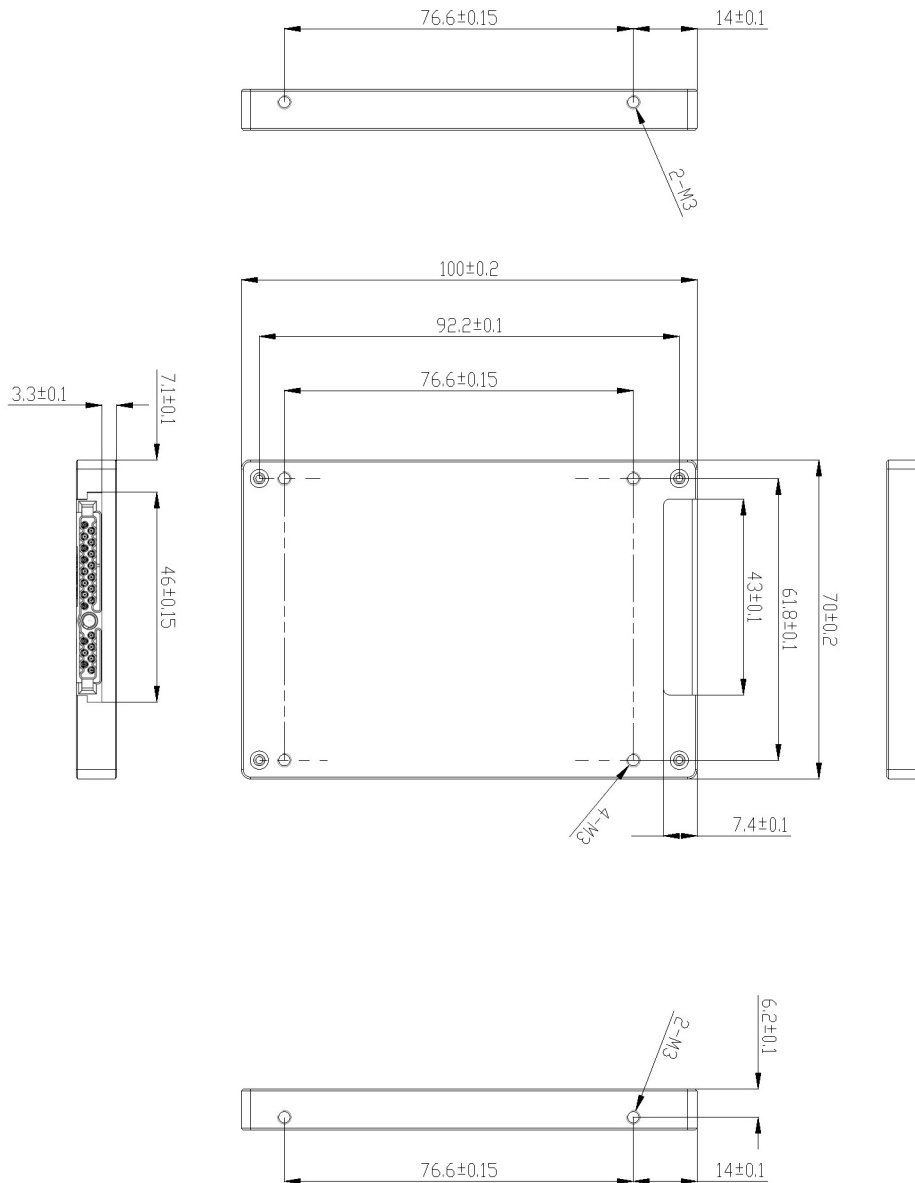

Length ( mm )	Width ( mm )	Height ( mm )
$100.20 \pm 0.25$	$69.80 \pm 0.25$	$9.30 \pm 0.1$

Table 3- 1: Physical Specification



#### 4. Interface

##### 4.1 Supported Standards

RC series 2.5" SATA 6Gbps rugged SSD complies with the following standards:

- > SATA 6Gbps, Revision 3.1
- > ATA Command Set ACS-2

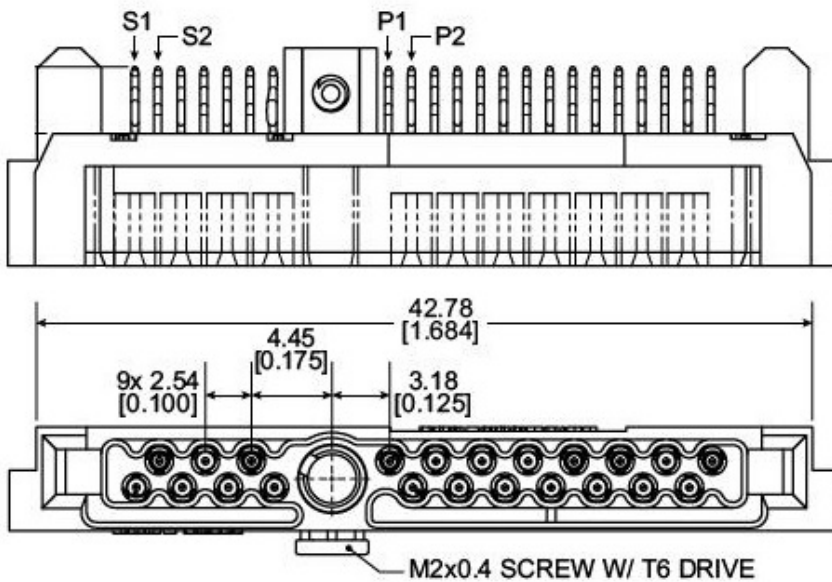

Figure 4- 1: Interface Specification



### 4.2 Pin Assignments

Pin number	Signal name	Description
<b>Signal Connector</b>		
S1	GND	2nd mate
S2	A+	Differential signal pair A From physical layer electronics
S3	A-	
S4	GND	2nd mate
S5	B-	Differential signal pair B From physical layer electronics
S6	B+	
S7	GND	2nd mate
<b>Power Connector</b>		
P1	V33	3.3V power (unused)
P2	V33	3.3V power (unused)
P3	V33	3.3V power, pre-charge,2nd mate(unused)
P4	GND	1st mate
P5	GND	2nd mate
P6	GND	2nd mate
P7	V5	5V power, pre-charge,2nd mate
P8	V5	5V power
P9	V5	5V power
P10	GND	2nd mate
P11	DAS/DSS	Device activity signal/Disable staggered spinal(unused)
P12	GND	1st mate
P13	V12	12V power, pre-charge,2nd mate(unused)
P14	V12	12V power(unused)
P15	V12	12V power(unused)

Table 4- 1: Pin Assignments Specifications

## 5. Environmental Specifications

### 5.1 Temperature

Parameter	Specifications
Operational	-40°C to 85°C
Storage	-55°C to 95°C

Table 5- 1: Temperature



5.2 Humidity

Parameter	Specifications
Operational/ Non-Operational	5%~95%(no condensation)

Table 5- 2: Humidity

5.3 Vibration

Parameter	Specifications
Operational/ Non-Operational	20G, 10-2,000 Hz random

Table 6- 3: Vibration

5.4 Shock

Parameter	Specifications
Operational	2,000G, 0.4 ms; 50 G, 11 ms

Table 5- 4: Shock

5.5 Altitude

Parameter	Specifications
Operational	80,000 feet

Table 5- 5: Altitude

5.6 Electrostatic Discharge (ESD)

Parameter	Test Voltage
Contact	2kv,4kv
Air	4kv,8kv

Table 5- 6: Electrostatic Discharge (ESD)



## 6. Reliability Characteristics

### 6.1 Error and Bad Block Management

The SSD soft error rate specification is much better than the hard disk drive specification. In the extremely rare case that a read error does occur, SSD will recover the data by using error detection code and error correction code (ECC). The hardware Error Correction Coding engine executes parity generation and error detection/correction features, and enhances decoding throughput and data reliability.

Bad blocks are occasionally created during the life cycle of a flash component, which called dynamic bad-block accumulation. These bad blocks must be marked and replaced dynamically in order to prevent read/write failures.

### 6.2 Global Wear-leveling

Global wear leveling is employed to maximize the life span of the device. It is a block management technique to even distribution of erase counts in all the flash blocks. It can move cold data (rarely accessed data) to a block with high erase counts to average the life of every block and enhance the data reliability.

### 6.3 Garbage Collection

Garbage collection that can keep spare and cache block in a best ratio for host command execution. This feature can prevent performance downgrade due to the device running out of spare blocks and maintain the performance in an optimized level. The garbage collection operations will be dynamically adjusted by threshold values based on different host commands and situations in order to keep the device always in high performance.

## 7. Supported ATA Commands

### 7.1 Command Set

Command	Code	Protocol
<b>General Feature Set</b>		
Execute Device Diagnostic	90h	Execute device diagnostic
Flush Cache	E7h	Non-data
Identify Device	ECh	PIO data-in
Initialize Drive parameters	91h	Non-data
Read DMA	C8h	DMA
Read Log Ext	2Fh	PIO data-in
Read Multiple	C4h	PIO data-in
Read Sectors	20h	PIO data-in
Read Verify Sectors	40h or 41h	Non-data



Set Feature	EFh	Non-data
Set Multiple Mode	C6h	Non-data
Write DMA	CAh	DMA
Write Multiple	C5h	PIO data-out
Write Sectors	30h	PIO data-out
NOP	00h	Non-data
Read Buffer	E4h	PIO data-in
Write Buffer	E8h	PIO data-out
<b>Power Management Feature Set</b>		
Check Power Mode	E5h or 98h	Non-data
Idle	E3h or 97h	Non-data
Idle Immediate	E1h or 95h	Non-data
Sleep	E6h or 99h	Non-data
Standby	E2h or 96h	Non-data
Standby Immediate	E0h or 94h	Non-data
<b>Security Mode Feature Set</b>		
Security Set Password	F1h	PIO data-out
Security Unlock	F2h	PIO data-out
Security Erase Prepare	F3h	Non-data
Security Erase Unit	F4h	PIO data-out
Security Freeze Lock	F5h	Non-data
Security Disable Password	F6h	PIO data-out
<b>SMART Feature Set</b>		
SMART Disable Operations	B0h	Non-data
SMART Enable/Disable Autosave	B0h	Non-data
SMART Enable Operations	B0h	Non-data
SMART Execute OFF-LINE Immediate	B0h	Non-data
SMART Read Log	B0h	PIO data-in
SMART Read Data	B0h	PIO data-in
SMART Read Threshold	B0h	PIO data-in
SMART Return Status	B0h	Non-data
SMART Save Attribute Values	B0h	Non-data
SMART Write Log	B0h	PIO data-out
<b>Host Protected Area Feature Set</b>		
Read Native Max Address	F8h	Non-data
Set Max Address	F9h	Non-data
Set Max Set Password	F9h	PIO data-out
Set max Lock	F9h	Non-data
Set Max Freeze Lock	F9h	Non-data
Set Max Unlock	F9h	PIO data-out
<b>48-bit Address Feature Set</b>		
Flush Cache Ext	EAh	Non-data
Read Sectors Ext	24h	PIO data-in



Read DMA Ext	25h	DMA
Read Multiple Ext	29h	PIO data-in
Read Native Max Address Ext	27h	Non-data
Read Verify Sectors Ext	42h	Non-data
Set Max Address Ext	37h	Non-data
Write DMA Ext	35h	DMA
Write Multiple Ext	39h	PIO data-out
Write Sectors Ext	34h	PIO data-out
<b>NCQ Feature Set</b>		
Read FPDMA Queued	60h	DMA Queued
Write FPDMA Queued	61h	DMA Queued
<b>Others</b>		
Data Set Management	06h	DMA
Seek	70h	Non-data

Table 7- 1: Command Set

## 7.2 Identify Data

Word	F/V	Default Value	Description
0	F	0040h	General configuration
1	X	XXXXh	Default number of cylinders
2	V	0000h	Reserved
3	X	00XXh	Default number of heads
4	X	0000h	Obsolete
5	X	0240h	Obsolete
6	F	XXXXh	Default number of sectors per track
7-8	V	XXXXh	Number of sectors per card (Word7=MSW, Word8=LSW)
9	X	0000h	Obsolete
10-19	F	XXXXh	Serial number in ASCII (Right justified)
20	X	0002h	Obsolete
21	X	0002h	Obsolete
22	X	0000h	Obsolete
23-26	F	XXXXh	Firmware revision in ASCII Big Endian Byte Order in Word
27-46	F	XXXXh	Model number in ASCII (left justified) Big Endian Byte Order in Word
47	F	8001h	Maximum number of sectors on Read/Write Multiple command
48	F	0000h	Reserved
49	F	0F00h	Capabilities
50	F	4000h	Capabilities
51	F	0200h	PIO data transfer cycle timing mode
52	X	0000h	Obsolete
53	F	0007h	Field validity



## Panther Military RC Series 2.5" SATA 6Gbps Rugged SSD Data Sheet

16



54	X	XXXXh	Current numbers of cylinders
55	X	XXXXh	Current numbers of heads
56	X	XXXXh	Current sectors per track
57-58	X	XXXXh	Current capacity in sectors (LBAs) Word57=LSW, WORD58=MSW)
59	F	0101h	Multiple sector setting
60-61	F	XXXXh	Total number of user addressable logical sectors for 28-bit command (DWord)
62	X	0000h	Reserved
63	F	0207h	Multiword DMA transfer Supports MDMA mode 0,1,2
64	F	0003h	Advanced PIO modes supported
65	F	0078h	Minimum Multiword DMA transfer cycle time per word
66	F	0078h	Recommended Multiword DMA transfer cycle time
67	F	0078h	Minimum PIO transfer cycle time without flow control
68	F	0078h	Minimum PIO transfer cycle time with IORDY flow control
69	F	4000h	Additional supported
70-74	F	0000h	Reserved
75	F	001Fh	Queue depth
76	F	070Eh	Serial ATA capabilities >Supports Serial ATA Gen3 >Supports Serial ATA Gen2 >Supports Serial ATA Gen1 >Supports Phy event counters log >Supports receipt of host initiated power management requests >Supports Native Command Queuing
77	F	0080h	Serial ATA additional capability >DevSleep_to_ReducedPwrState
78	F	0148h	Serial ATA features supported >supports Device Sleep >Supports software settings preservation >Device supports initiating power management
79	V	0040h	Reserved
80	F	03F0h	Major version number(ACS-2)
81	F	0000h	Major version number
82	F	742Bh	Command sets supported 0
83	F	7500h	Command sets supported 1
84	F	4023h	Command sets supported 2
85-87	V	XXXXh	Command set/feature enabled
88	V	007Fh	Ultra DMA mode supported and selected
89	F	0003h	Time required for a Normal Erase Mode Security Erase Unit command
90	F	0001h	Time required for an Enhanced Erase Mode Security





			Erase Unit command
91	V	0000h	Current advanced power management value
92	V	FFFEh	Master password identifier
93-99	V	0000h	Reserved
100-103	V	XXXXh	Maximum user LBA for 48-bit address feature set
104	V	0000h	Reserved
105	F	0100h	Maximum number of 512-byte blocks per Data Set Management Command
106-127	V	0000h	Reserved
128	V	0001h	Security status
129-159	X	XXXXh	Vendor specific
160	F	0000h	Power requirement description
161	X	0000h	Reserved
162	F	0000h	Key management schemes supported
163	F	0000h	CF Advanced True IDE timing mode capability and setting
164-168	F	0000h	Reserved
169	F	0001h	Data Set Management supported
170-216	V	XXXXh	Reserved
217	F	0001h	Non-rotating media(SSD)
218-221	X	0000h	Reserved
222	F	107Fh	Transport major revision (SATA Rev 3.1)
223-254	X	0000h	Reserved
255	X	XXXXh	Integrity word

Table 7- 1: Identify Data Value

**Notes:**

F: content (byte) is fixed and does not change.

V: content (byte) is variable and may change depending on the state of device or the commands executed by the device.

X: Content (byte0 is vendor specific and may be fixed or variable.

**7.3 SMART Feature Set**

If the reserved size is below the threshold, the status can be read from the Cylinder Register using the Return Status command (DAh).

Value	Command	Value	Command
D0h	Read Data	D5h	Read Log
D1h	Read Attribute Threshold	D6h	Write Log
D2h	Enable/Disable Autosave	D8h	Enable SMART Operations
D3h	Save Attribute Values	D9h	Disable SMART Operations
D4h	Execute OFF-LINE Immediate	DAh	Return Status

Table 7- 3: Smart Feature Set



### 7.4 SMART Data Structure

The following 512 bytes make up the device SMART data structure. Users can obtain the data using the command "Read Data" command (D0h).

Byte	F/V	Description
0-1	X	Revision code
2-361	X	Vendor specific
362	V	Off-line data collection status
363	X	Self-test execution status byte
364-365	V	Total time in seconds to complete off-line data collection activity
366	X	Vendor specific
367	F	Off-line data collection capability
368-389	F	SMART capability
370	F	Error logging capability >7-1 Reserved > 1=Device error logging supported
371	X	Vendor specific
372	F	Short self-test routine recommended polling time (in minutes)
373	F	Extended self-test routine recommended polling time (in minutes)
374	F	Conveyance self-test routine recommended polling time (in minutes)
375-385	R	Reserved
386-395	F	Firmware version/data code
396-399	F	Reserved
400-405	F	"SM2246"
406-510	X	Vendor specific
511	V	Data structure checksum

Table 7- 4: Smart Data Structure

**Notes:**

F: content (byte) is fixed and does not change.

V: content (byte) is variable and may change depending on the state of device or the commands executed by the device.

X: Content (byte) is vendor specific and may be fixed or variable.

R: content (byte) is reserved and shall be zero.



**7.5 SMART Attributes**

The following table defines the vendor specific data in byte 2 to 361 of the 512-byte SMART data.

Attribute ID	Raw Attribute Value								Description
	Decimal	hex							
1	01	MSB	00	00	00	00	00	00	Read Error Rate
5	05	LSB	MSB	00	00	00	00	00	Reallocated sector count
9	09	LSB			MSB	00	00	00	Power on hours count
12	0C	LSB			MSB	00	00	00	Power cycle count
160	A0	LSB			MSB	00	00	00	Uncorrectable sector count when read/write
161	A1	LSB	MSB	00	00	00	00	00	Number of valid spare block
163	A3	LSB	MSB	00	00	00	00	00	Number of initial invalid block
164	A4	LSB			MSB	00	00	00	Total erase count
165	A5	LSB			MSB	00	00	00	Maximum erase count
166	A6	LSB			MSB	00	00	00	Minimum erase count
167	A7	LSB			MSB	00	00	00	Average erase count
168	A8	LSB			MSB	00	00	00	Max erase count of spec
169	A9	LSB			MSB	00	00	00	Remain Life(percentage)
175	AF	LSB			MSB	00	00	00	Program fail count in worst die
176	B0	LSB	MSB	00	00	00	00	00	Erase fail count in worst die
177	B1	LSB			MSB	00	00	00	Total wear level count
178	B2	LSB	MSB	00	00	00	00	00	Runtime invalid block count
181	B5	LSB			MSB	00	00	00	Total program fail count
182	B6	LSB	MSB	00	00	00	00	00	Total erase fail count
187	BB	LSB			MSB	00	00	00	Uncorrectable error count
192	C0	LSB	MSB	00	00	00	00	00	Power-off retract count
194	C2	MSB	00	00	00	00	00	00	Controlled temperature
195	C3	LSB			MSB	00	00	00	Hardware ECC recovered
196	C4	LSB			MSB	00	00	00	Reallocation event count
198	C6	LSB			MSB	00	00	00	uncorrectable error count off-line
199	C7	LSB	MSB	00	00	00	00	00	UltraDMA CRC error count



225	E1	LSB						MSB	Total LBAs written (each write unit=32MB)
232	E8	LSB	MSB	00	00	00	00	00	Available reserved space
241	F1	LSB						MSB	Total LBAs written (each write unit=32MB)
242	F2	LSB						MSB	Total LBAs read (each write unit=32MB)

Table 7- 5: Smart Attributes

### 8. Ordering Information

Model Name	Capacity	Part Number
<b>RC Series MLC</b>	16GB	SD-MG25RC16M
	32GB	SD-MG25RC32M
	64GB	SD-MG25RC64M
	128GB	SD-MG25RC128M
	256GB	SD-MG25RC256M
	512GB	SD-MG25RC512M
	1TB	SD-MG25RC1024M

Table 8- 1: Ordering information

